

ZENITH TRANS-OCEANIC

All Models

A-B Battery Supply

90 VOLT B+ / 9 VOLT A+

INCLUDES OPTIONAL POWER SUPPLY FOR DIAL LIGHT CIRCUIT



**INSTRUCTIONS
PARTS LIST
BATTERY LAYOUTS
WIRING DIAGRAMS
TEMPLATES FOR Z-985 CONNECTOR**

© 2007 Ed Morris

**Complete instructions are also available online in
.pdf format (Adobe Reader required) at
www.edsantiqueradios.com**

90 Volt / 9 Volt A-B Battery

Instructions

The Zenith Z-985 AB battery and all compatible batteries, such as the Eveready 752 and RCA VS-047, work in all models of the Zenith Transoceanic. The 8G005 series requires an additional 1.5-volt battery in series with the A (filament) supply. Decide how you want to connect your battery to your Zenith Trans-Oceanic. There are two basic choices for connecting your battery to your radio:

- A. For the highest level of authenticity, use an original or replica Z-985 type male connector, available at www.edsantiqueradios.com
- B. No connector. Install 1/8" x 1/2" pins on the ends of the 90v B+, 9v A+, and combined B- leads from your battery and connect directly to the Zenith female connector. This does not alter your Zenith in any way and avoids the hassle of building a replica connector. However, it is essential to color code your battery leads and the connector to avoid the chance of incorrectly connecting the leads and seriously damaging your tubes and/or radio.

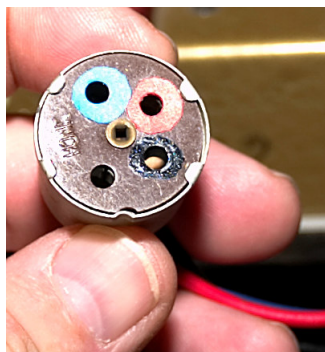

Photo 1. Color-coded terminal holes on Zenith Female connector

Step 1. Decide what kind of batteries you will use for the 90-volt B power supply. You can use ten 9 volt batteries or 60 AA batteries. Ten 9-volt batteries will power your radio for 30 to 40 hours. The AA batteries have more amperage and will last about ten times longer (400+ hours). The downside is that you will need to find AA battery holders and it's a tight fit in the box, but it can be done. If you are planning to use AA batteries, purchase six 5 x 2 AA battery holders and six single D battery holders. The wiring is basically the same for AA batteries or 9 volt batteries. The batteries are wired in series. There are holders available in various configurations for AA and D batteries, and holders that hold more than one battery are already wired in series, so you only need to wire the holders themselves in series with the connector. Refer to the wiring diagram included with these instructions.

Step 1A. Prepare the A supply. The A supply powers the filaments in the tubes. The A supply requires a total of 9 volts. Six D cells work well for the A power supply (see note below if you will be using this battery in a 8G005 series radio). Six single or two 3x1 D cell holders will work if you are using 60 AA's for the B supply. If you are using 9 volt cells for the B supply, you have much more room in the box for D cells, and you can use any combination of holders that will fit. Don't use a 3x2 D cell holder, though, as it won't fit in the box. Whatever combination you choose, you must have at total of six D batteries in series, giving you $1.5v \times 6 = 9$ volts for the A supply to the tube filaments.

Note: For the 8G005 series, you will also need a separate D cell which must connect to the separate two-prong connector coming from the large battery plug on your radio. The small connector is wired in series with the A+ side of the large plug. Your radio will not operate unless a 1.5v battery is connected to this small plug. The additional battery is required because the 8G005 series have more tubes than the later models.

Connect the holders in series. Refer to the wiring diagrams at the end of this document for detailed wiring schematics.

Figure 1. Generic diagram for connecting multi-cell holders

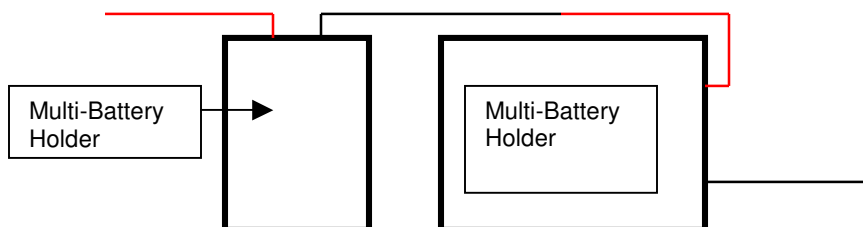

Step 1B. Prepare the B supply using six 5x2 AA battery holders or ten Radio Shack #2700325 9v battery clips. Now connect and solder each black lead to a red lead of another battery holder or clip until you have a chain of six AA battery holders or ten 9v battery clips soldered together

black to red. If you are using 9v batteries, build a cardboard box to hold the ten 9v cells (see photo 3a. below) or use a plastic box of the right size. You won't need a box for the AA holders. Be very careful to avoid a shock when handling the free ends of the leads from the B supply.

Figure 2a. Diagram for connecting 9v battery clips in series

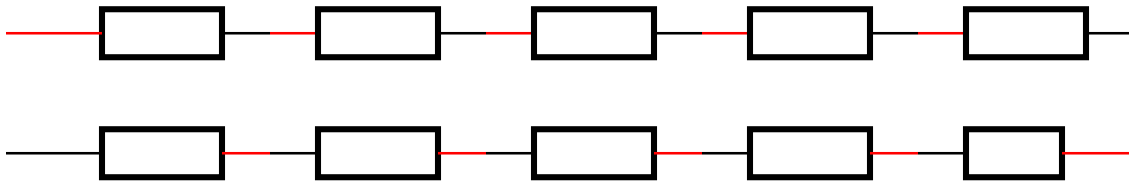
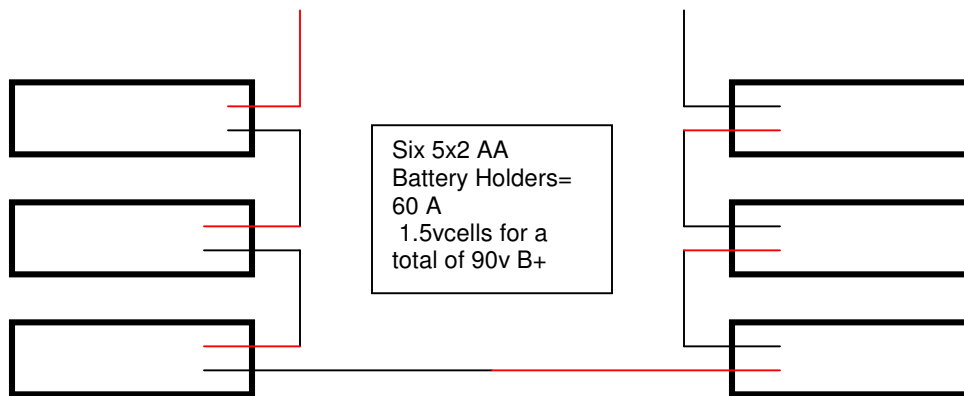

Figure 2b. Diagram for connecting six 5x2 AA holders in series



Step 2. If the connector hole in the battery box has not been cut out, cut it out now. The Zenith female connector requires a 1-5/16" hole to pass through. If you built or purchased a replica connector, hot glue it to the inside of the box.

Step 3A. Go to Step 3B if you used AA batteries for the B supply. Place the single D cell holder in the battery box and connect the leads to the dial light connector. Use small insulated alligator clips or fabricate a suitable connector to fasten the 1.5 volt D battery to the terminals of the dial light circuit. Carefully tuck them inside the left side of the battery compartment and make sure the clips aren't touching. For a more authentic setup, you can purchase a replica, working Z-1 battery at www.edsantiqueradios.com to power the 600 series dial light circuit or to use for the extra filament battery in 8G005 series radios.

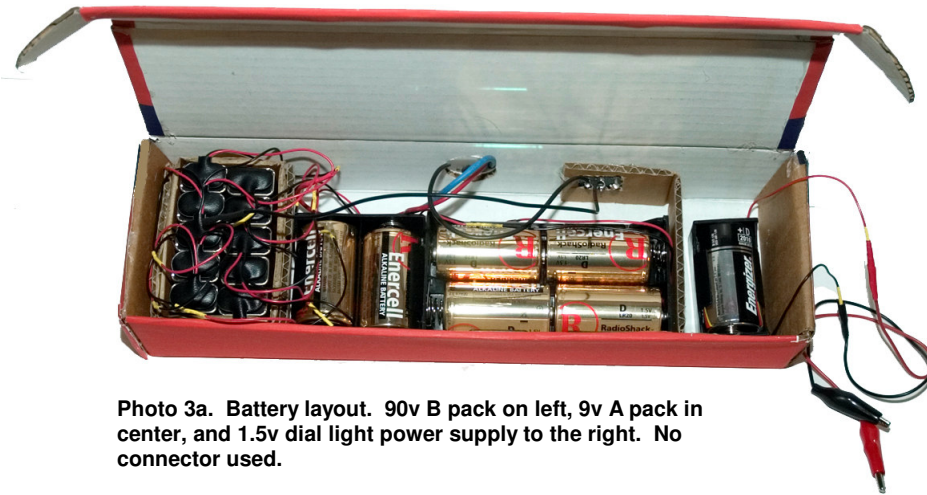

Photo 3a. Battery layout. 90v B pack on left, 9v A pack in center, and 1.5v dial light power supply to the right. No connector used.



Photo 3b. Alternate battery layout using 60AA batteries in place of the ten 9 volt batteries. The dial light D cell is omitted due to space limitations, but you can purchase my Z-1 replica 1.5v cell to power the dial light circuit of 600 series or the filament string in the 8G005 series.

Step 3B. Place three AA holders in each end of the box as shown in Photo 3b, above. Place six single D cell holders in the center of the box, three on each side of the connector. If three single holders won't fit side by side, arrange them as shown in the wiring diagram at the end of these instructions. The six D cell holders are wired in a series string as are the six AA holders (each AA holder holds ten batteries, five per side.).

Step 4. Install the completed battery in the battery compartment and plug the radio plug into the battery connector. Set the radio to the BC band and turn on

the radio. If it does not come in within 5 to 10 seconds, turn the radio off and check your battery wiring and connections.

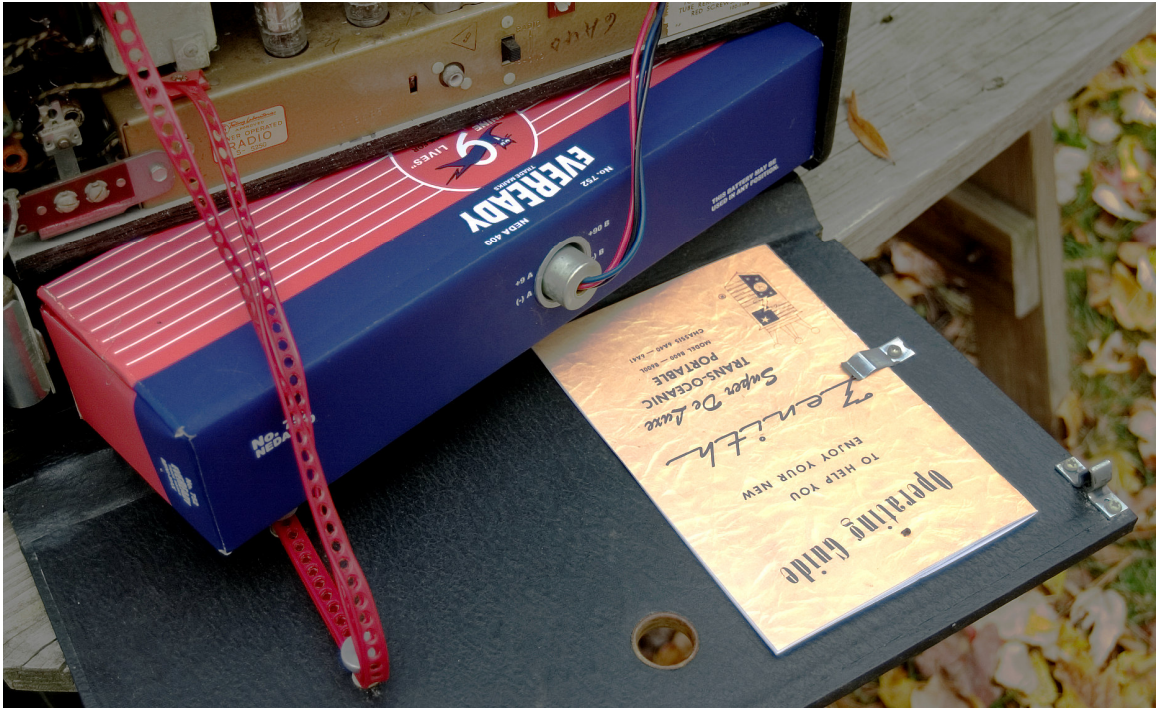

Photo 4. Completed battery installed in Trans-Oceanic. This photo shows a replica Z-985 connector installed in battery box.

Warning

Make sure that your radio is turned off when connecting or disconnecting the AB battery or when inserting or removing the AC power plug from the battery switchover receptacle.

A-B Battery Parts List

This list is for reference. You may not need all these parts, depending upon which kind of batteries you are using for the B power supply (9 volt or AA).

PARTS LIST

<i>Radio Shack #</i>	<i>QTY</i>	<i>Item Description</i>
2700325	2 ea	Pkg/5 9v battery clips
2700389	1 ea	Plastic battery holder, 4 D cells
2700389	1 ea	Plastic battery holder, 2 D cells
2700402	1 ea	Plastic battery holder, 1 D cell (optional for dial light)
275401	1 ea	SPST slide switch
274321	1 ea	Pkg/8 RCA phono plugs (3 needed)

AA BATTERY HOLDERS

MS-BH-10-AA 6 ea Thomas Distributing Battery & Electronics
(verify part # make www.nimhbattery.com
sure you get 5x2 holders 1-800-821-2769

5x2 AA holders Strikalite
 www.strikalite.co.uk
 (01543)683122

CONNECTOR

Z-985 Connector www.edsantiqueradios.com
(replica)

WIRES

Red, Black, and Blue (or other color to match the 90v B+ lead on your model radio) hook-up wire
Solder
Shrink tubing

TOOLS

Soldering gun
Wire strippers
Needle nose pliers
Hobby Knife
Hot glue

BATTERIES

90 Volt B Supply	10 ea	9v alkaline cells
or	60 ea	1.5v AA alkaline cells

9 Volt A Supply	6 ea	1.5 alkaline D cells
Dial Light Supply	1 ea	1.5 alkaline D cell (optional)

Zenith Connector Templates

Copy and use if you are building a replica connector.
For instructions to build your own replica connector, go
to www.njarc.org/broadcaster/BC0702.pdf, page 6.

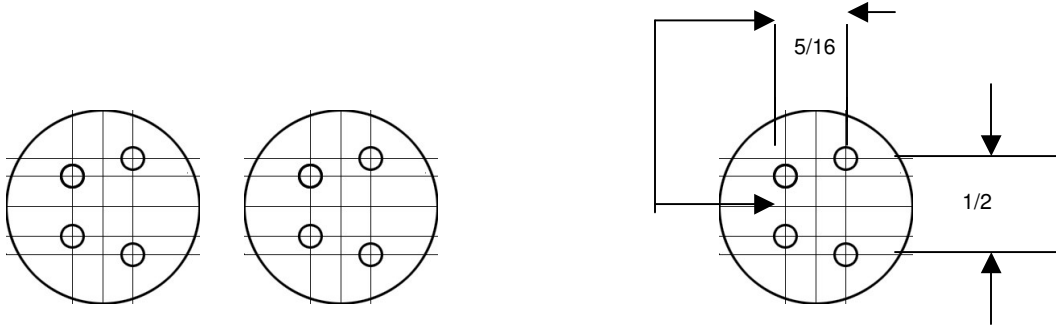

Battery Layout and Wiring Diagram for 60 AA B Power Supply and Single D cell holders for A Power Supply

(Not to Scale)

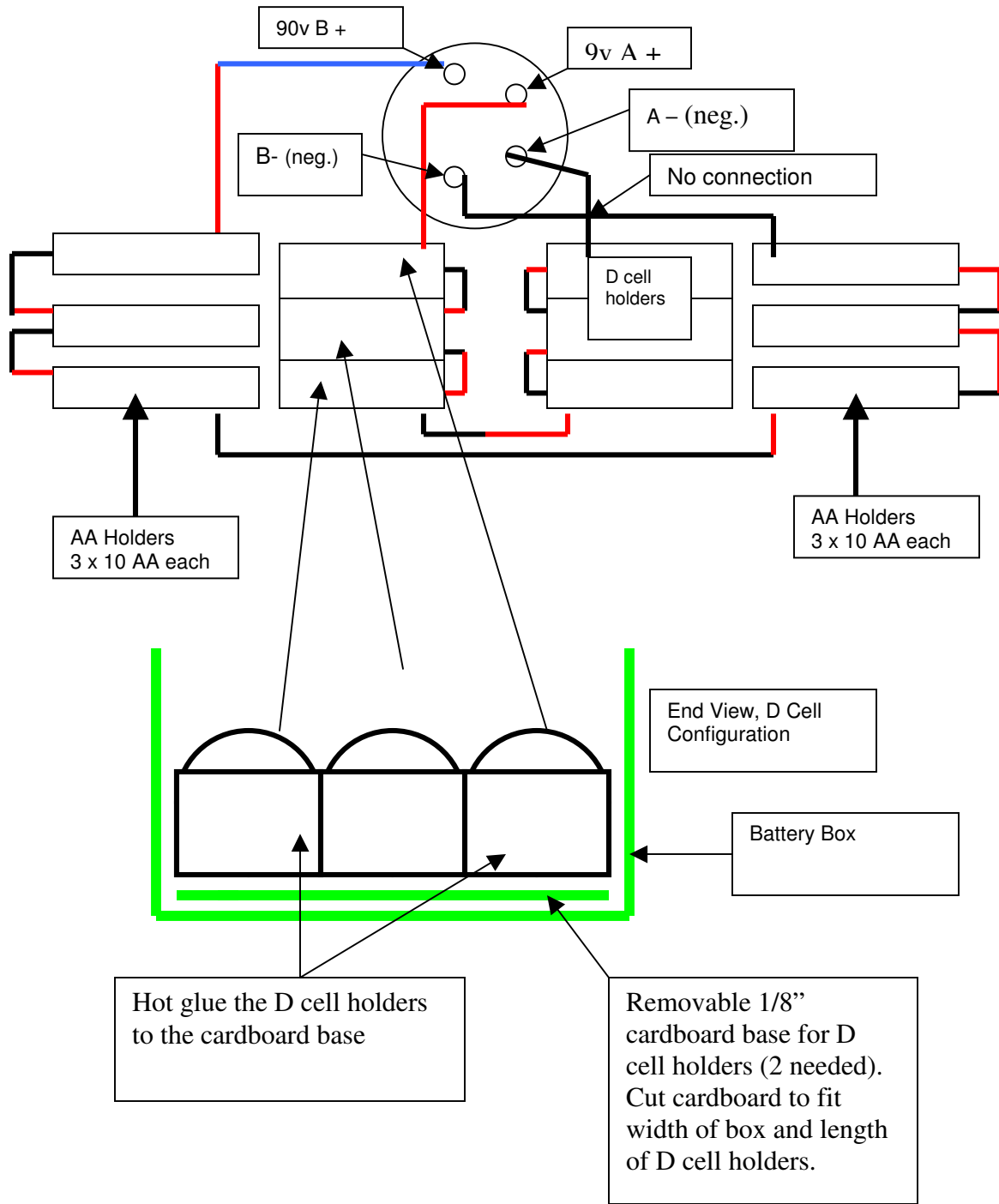

**Battery Layout and Wiring Diagram for
9 volt x 10 B Power Supply and 6 D Cell A Supply
No Connector Used
Not to Scale**

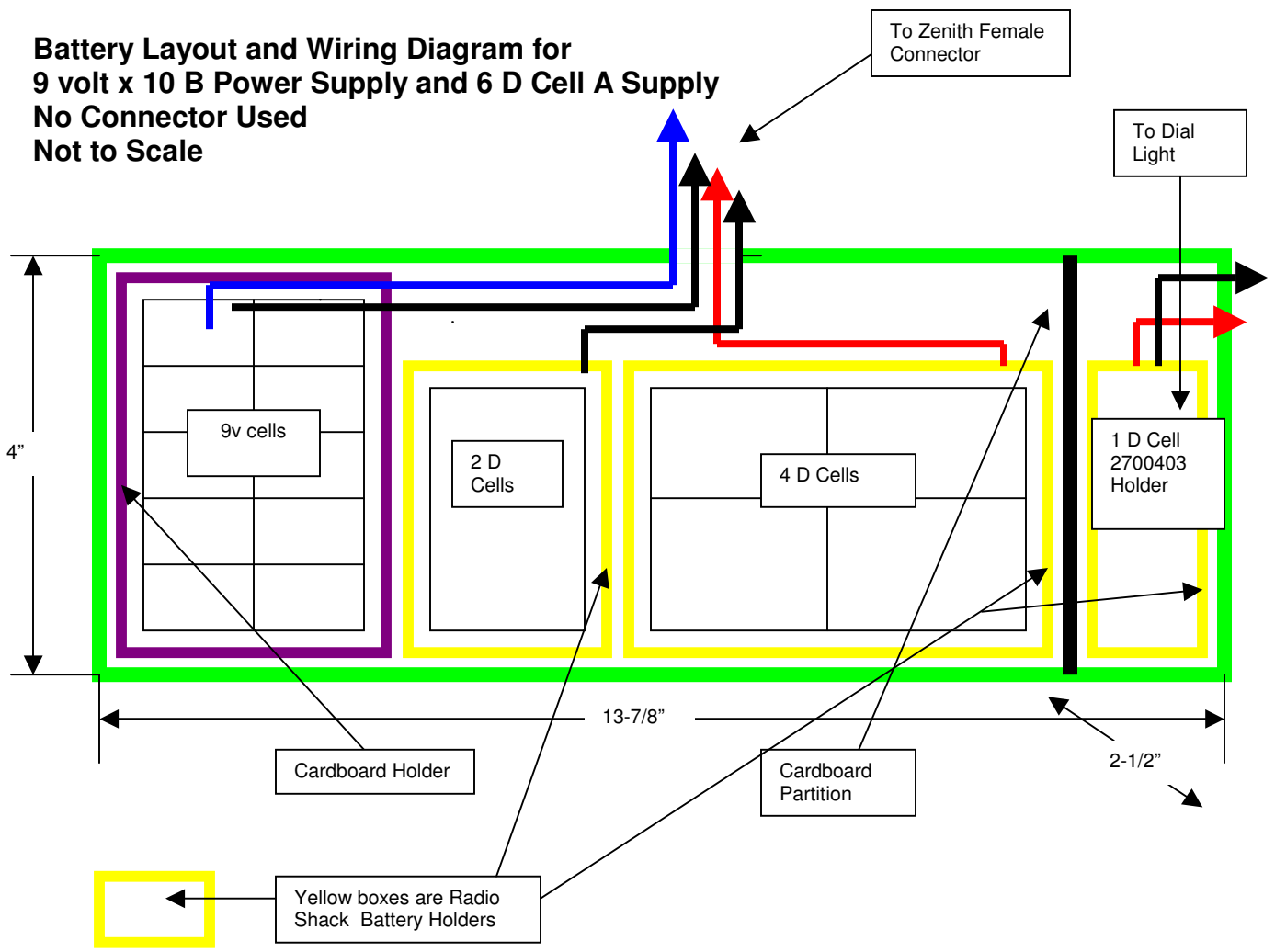

Wiring Diagram for 90v/9v A-B Battery, 60 AA cell B Supply Version

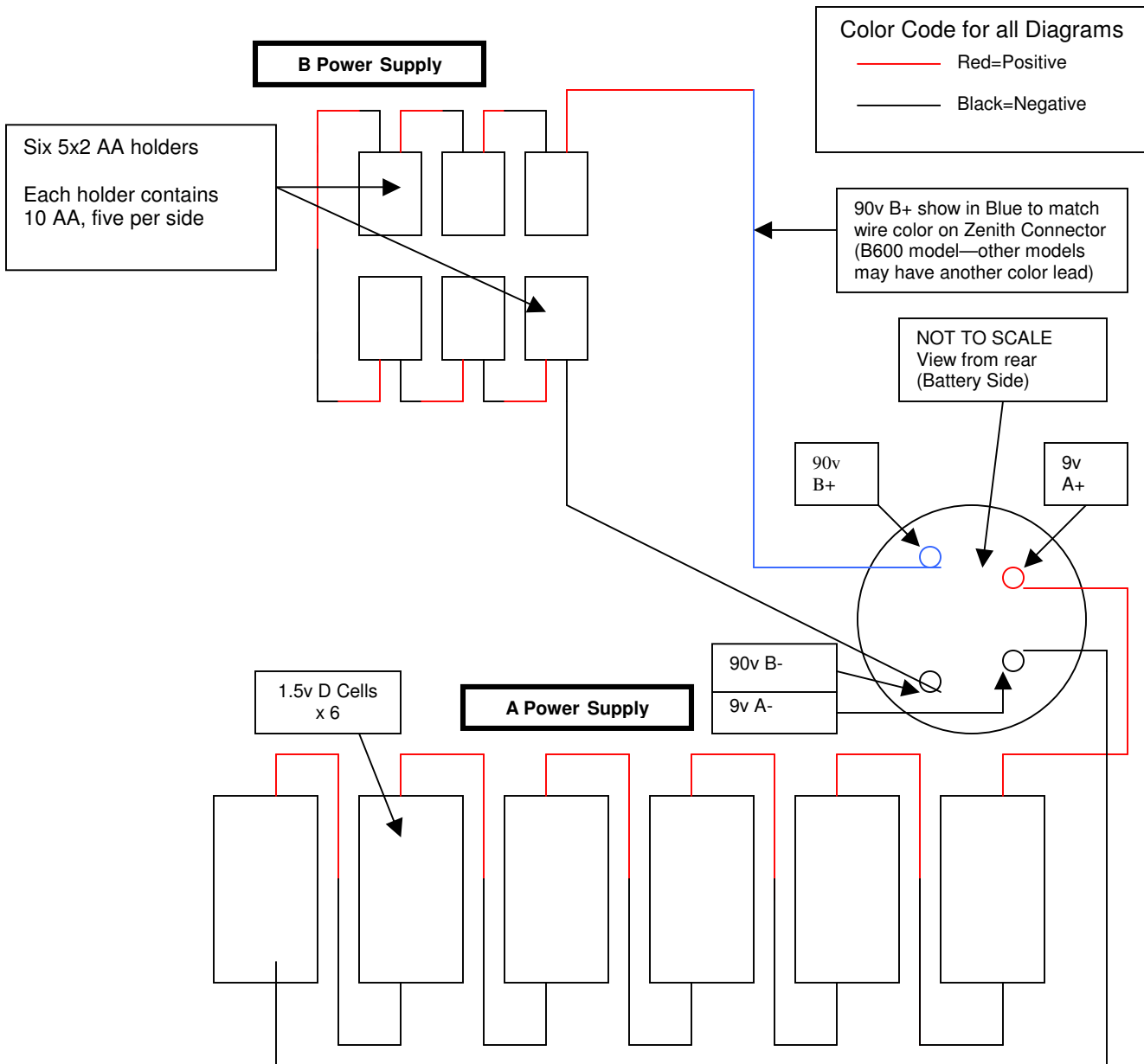

Dial Light Wiring Diagram

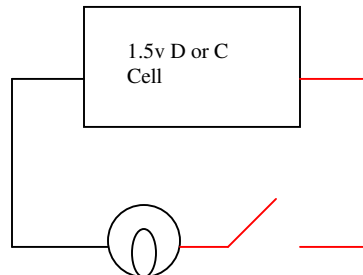

AB Battery and Connector Trouble Shooting Guide

Step 1. Check voltages at battery side male connector

There should be 90 vdc between the B+ and B- pins
There should be 9 vdc between the A+ and A- pins

If voltages are correct, go to step 3

Step 2. If voltages are incorrect, check for the following:

- Weak or dead batteries
- Incorrectly inserted batteries
- Incorrectly wired battery holders
- Bad joints or connections
- Defective connector (return for replacement or refund)

Step 3. If voltages at male connector are correct, check the radio side female connector

- Pins not mating with female socket contacts
- Dirty or corroded contacts in the female socket
- Open connections in female socket connector

Step 4. Is your radio a 500 or 600 series Trans-Oceanic? These radios have a resistor embedded in the body of the female socket connector to augment B+ voltage and prevent accidental filament burnout when switching between AC and battery power. Check the value of the resistor between the A+ and B- pins in the female connector. It may have drifted upwards due to aging. The value should be 100 ohms. If the resistance is too high, it may decrease plate voltage below acceptable levels. Replace the resistor. This requires disassembly of the female socket connector.

You may also bypass the resistor by connecting the B- lead from the B power supply to the A- pin as shown below. If the radio now works properly, the problem is with the resistor or connection between the A+ and B- pins. There is no difference in the operation of the radio with the negative leads from the A and B power supplies both connected to the A- pin. To prevent accidental filament burnout, always turn radio off when connecting or disconnecting the battery or switching between AC and battery power.

